

976nm 540W High Power Fiber Coupled Diode Laser
RPK976S-540.0W-20022-NA

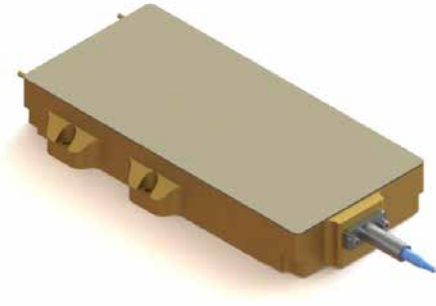

Features:

- ◆ 976nm wavelength
- ◆ 540W output power
- ◆ 200µm fiber core diameter
- ◆ 0.22NA
- ◆ 1020nm-1200nm feedback protection

Applications:

- ◆ Fiber laser pumping

High Power Diode Laser Modules are manufactured by adopting specialized fiber-coupling techniques, resulting in volume products with a high efficiency, stability and superior beam quality. The products are achieved by transforming the asymmetric radiation from the laser diode chip into an output fiber with small core diameter by using special micro optics. Inspecting and burn-in procedures in every aspect come to a result to guarantee each product with the reliability, stability and long lifetime.

Our research staffs are constantly improving and innovating the processing technology in the producing process, based on the professional knowledge and experience accumulated in long-terms. We are also continuously developing new products to meet customers' specific needs.

High quality products with reasonable price is our always goal.

976nm 540W High Power Fiber Coupled Diode Laser
RPK976S-540.0W-20022-NA

Specifications(25°C)		Symbol	Unit	RPK976S-540.0W-20022-NA		
				Minimum	Typical	Maximum
Optical Data ⁽¹⁾	CW Output Power	P_o	W	540	-	-
	Center Wavelength	λ_c	nm	976±3		
	Spectral Width (FWHM)	$\Delta\lambda$	nm	-	4	6
	Wavelength Shift with Temperature	$\Delta\lambda/\Delta T$	nm/°C	-	0.3	-
	Wavelength Shift with Current	$\Delta\lambda/\Delta I$	nm/A	-	0.6	-
	95% Power in NA	NA	NA	-	-	0.18
Electrical Data	Electrical-to-Optical Efficiency	η	%	-	48	-
	Threshold Current	I_{th}	A	-	1.3	-
	Operating Current	I_{op}	A	-	28	30
	Operating Voltage	V_{op}	V	-	41	43
	Slope Efficiency	η_D	W/A	-	20	-
Fiber Data	Core Diameter	D_{core}	µm	-	200	-
	Cladding Diameter	D_{clad}	µm	-	220	-
	Fiber Loose Tubing Diameter	-	mm	0.9		
	Numerical Aperture	N.A.	-	-	0.22	-
	Total Fiber Length	-	m	-	2.0	-
	Bending Radius	-	mm	88	-	-
	Fiber Termination	-	-	-	FF	-
Feedback Isolation	Wavelength Range	λ	nm	1020-1200		
	Isolation	-	dB	-	30	-
Others	ESD	-	V	-	-	500
	Storage Temperature ⁽²⁾	T_{st}	°C	-20	-	70
	Lead Soldering Temperature	-	°C	-	-	260
	Lead Soldering Time	-	sec	-	-	10
	Operating Temperature ⁽³⁾	T_{op}	°C	15	-	35
	Relative Humidity	-	%	15	-	75

(1) Data measured under operation output at 540W@25°C.

(2) A non-condensing environment is required for operation and storage.

(3) Operating temperature defined by the package housing. Acceptable operating range is 15°C~35°C, but performance may vary.

976nm 540W High Power Fiber Coupled Diode Laser
RPK976S-540.0W-20022-NA

Package Dimensions (Unit: mm)

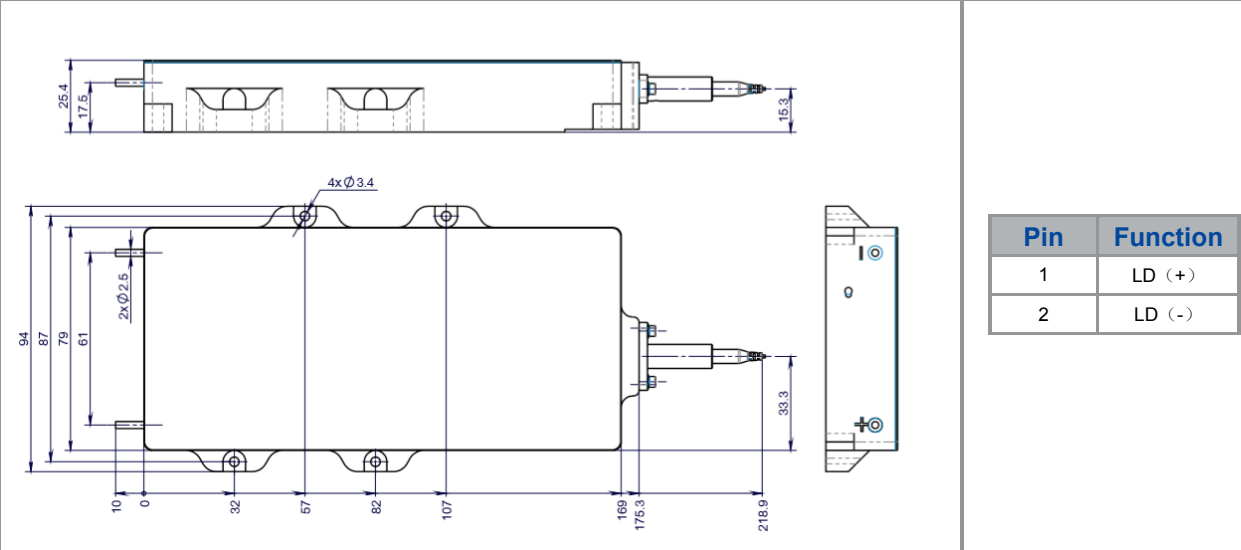

OPERATING NOTES

- ◆ Avoid eye and skin exposure to direct radiation during operation.
- ◆ ESD precautions must be taken during storage, transportation and operation.
- ◆ Please connect pins to wires by solder instead of using socket when operation current is higher than 6A. Soldering point should be close to the middle of the pins. Soldering temperature should be lower than 260°C and time shorter than 10 second.
- ◆ Make sure the fiber output end is properly cleaned before operation of laser. Follow safety protocols to avoid injury when handling and cutting the fiber.
- ◆ Use constant current power supply to avoid surge current during operation.
- ◆ Laser diode must be used according to the specifications.
- ◆ Laser diode must work with good cooling.
- ◆ Operation temperature ranges from 15°C to 35°C .
- ◆ Storage temperature ranges from -20°C to +70°C .

