

## 976nm 60W Wavelength-Stabilized High Power Fiber Coupled Diode Laser

**RPK976S-60.00W-10522-NA**

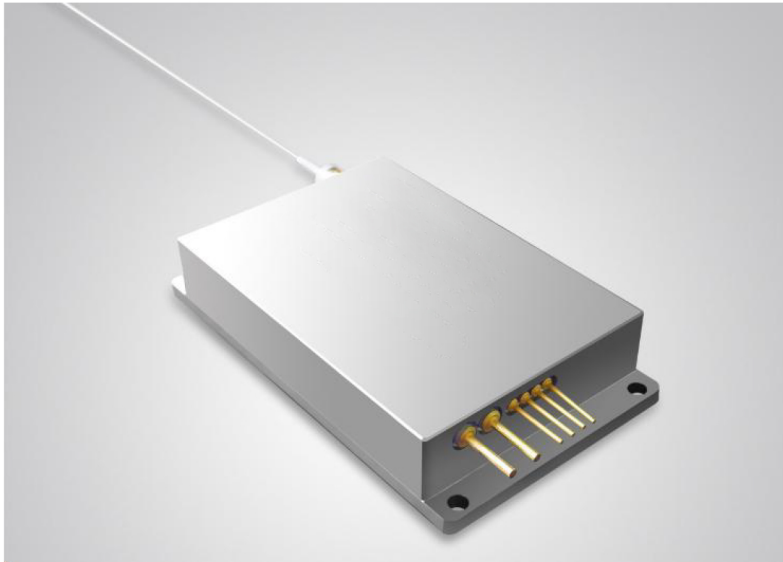

### Features:

- ◆ 976nm wavelength
- ◆ 60W output power
- ◆ 105 $\mu$ m fiber core diameter
- ◆ 0.22N.A.
- ◆ Narrow bandwidth  $\Delta\lambda \leq 0.7$ nm
- ◆ 1040nm-1200nm feedback protection

### Applications:

- ◆ Fiber laser pumping

High Power Diode Laser Modules are manufactured by adopting specialized fiber-coupling techniques, resulting in volume products with a high efficiency, stability and superior beam quality. The products are achieved by transforming the asymmetric radiation from the laser diode chip into an output fiber with small core diameter by using special micro optics. Inspecting and burn-in procedures in every aspect come to a result to guarantee each product with the reliability, stability and long lifetime.

Our research staffs are constantly improving and innovating the processing technology in the producing process, based on the professional knowledge and experience accumulated in long-terms. We are also continuously developing new products to meet customers' specific needs.

High quality products with reasonable price is our always goal.

## 976nm 60W Wavelength-Stabilized High Power Fiber Coupled Diode Laser

### RPK976S-60.00W-10522-NA

Specifications(25°C)	Symbol	Unit	RPK976S-60.00W-10522-NA			
			Minimum	Typical	Maximum	
<b>Parameter<sup>(1)</sup></b>	CW Output Power	$P_o$	W	60	-	-
	Threshold current	$I_{th}$	A	-	1	-
	Operating current	$I_{op}$	A	-	-	14
	Operating voltage	$V_{op}$	V	-	-	14
	Reverse Voltage	$V_{re}$	V	-	17.5	-
	Slope Efficiency	$\eta$	W/A	-	5.5	-
	Electrical-to-Optical Efficiency	PE	%	-	45	-
	Center wavelength	$\lambda_c$	nm	975.5	-	976.5
	Spectral width(FWHM)	$\delta\lambda$	nm	-	0.7	-
	Back reflection wavelength Range	$\lambda$	nm	1040	-	1200
	Back reflection isolation	-	dB	-	30	-
	Wavelength Shift with Temperature	-	nm/°C	-	0.02	-
	Light within 0.15NA	-	%	-	95	-
	Life Time	MTTF	hrs	-	100000	-
<b>Fiber Date</b>	Buffer diameter	$D_{buf}$	$\mu\text{m}$	-	250	-
	Cladding diameter	$D_{clad}$	$\mu\text{m}$	-	125	-
	Core diameter	$D_{core}$	$\mu\text{m}$	-	105	-
	Numeric aperture	NA	-	-	0.22	-
	Fiber length <sup>(2)</sup>	$l_f$	m	-	1	-
	Fiber Bend Radius	-	mm	37.5	-	-
<b>Others</b>	ESD	$V_{esd}$	V	-	-	500
	Storage temperature	$T_{stg}$	°C	-20	-	70
	Lead Soldering Temp	$T_{ls}$	°C	-	-	260
	Lead Soldering Time	t	sec	-	-	10
	Operating case temperature	$T_{op}$	°C	25	-	30
	Relative Humidity	RH	%	15	-	75

(1) Data measured under operation output at 60W.

(2) Other fibers available upon request.

## 976nm 60W Wavelength-Stabilized High Power Fiber Coupled Diode Laser

RPK976S-60.00W-10522-NA

### Characteristics

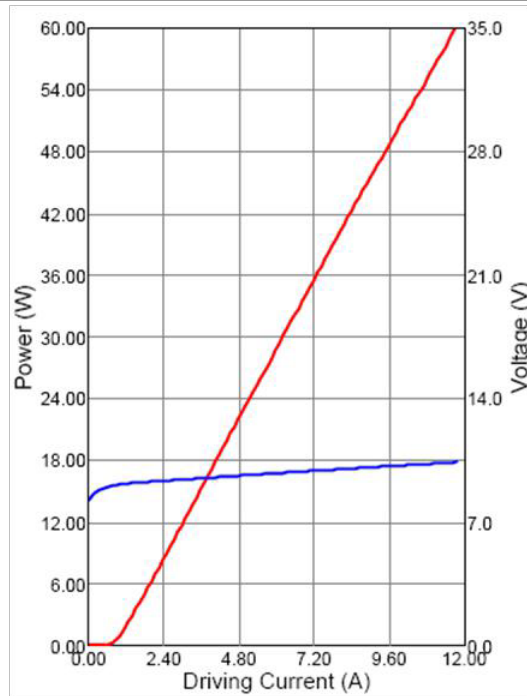

### Typ. spectrum

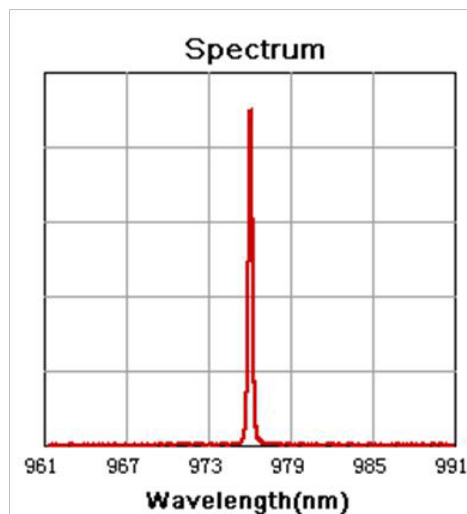

## 976nm 60W Wavelength-Stabilized High Power Fiber Coupled Diode Laser

**RPK976S-60.00W-10522-NA**

**Package Dimensions (mm)**

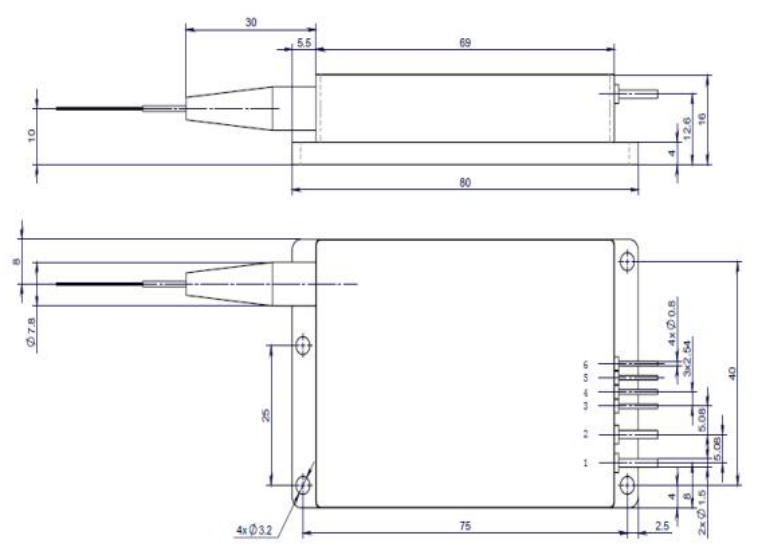

Pins	Function
1	LD ( + )
2	LD ( - )
3	Thermistor*
4	Thermistor*
5	PD ( N ) *
6	PD ( P ) *

\*: Optional function.

### OPERATING NOTES

- ◆ Avoid eye exposure to direct or scattered radiation.
- ◆ ESD precautions must be taken.
- ◆ Please connect pins to wires by solder instead of using socket when operation current is higher than 6A.
- ◆ Soldering point should be close to the root of the pins. Soldering temperature should be lower than 260°C and time shorter than 10 second.
- ◆ Use constant current power supply. Avoid surge current.
- ◆ Laser diode must be used according to the specifications.
- ◆ Laser diode must work with good cooling.
- ◆ Operation temperature is 25°C~ 30°C.
- ◆ Storage: -20°C~ +70°C, all pins short-circuit.

