

1568nm DM LASER

REP1568-DM-B

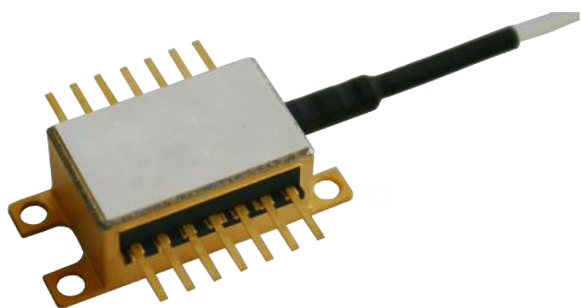

www.rpmclasers.com



SUPERIOR PERFORMANCE

RPMC Lasers REP1568-DM-B laser diode, available in the 1560 - 1573nm range, is a cost effective, highly coherent laser source, designed using RPMC's discrete-mode (DM) technology. Excellent SMSR and linewidth performance make it suitable for a wide variety of applications.

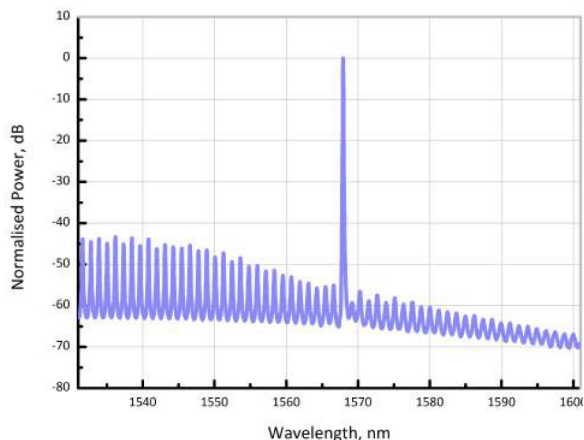

Typical optical spectrum at 25° C

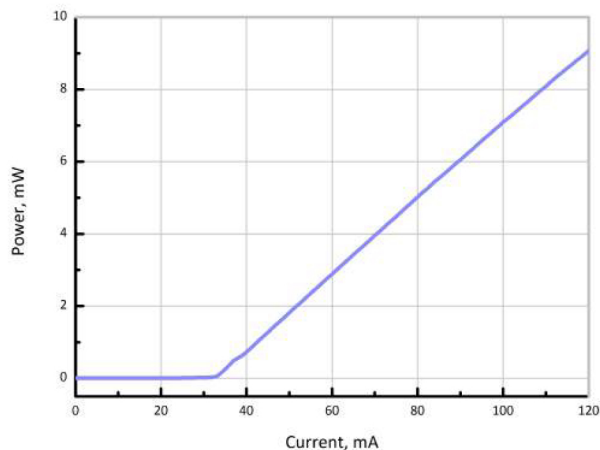

Output power as a function of bias current

ELECTRO-OPTICAL CHARACTERISTICS* ($T_{SUB} = 25^{\circ} C$)

PARAMETER	SYMBOL	MIN	TYP	MAX	UNIT
Centre Wavelength Range	λ	1560	1568	1573	nm
Wavelength specification	λ_{spec}	$\lambda - 1$	λ	$\lambda + 1$	nm
Side Mode Supression Ratio	SMSR	30	40	-	dB
Threshold Current	I_{th}	-	30	35	mA
Output Power in fiber	P_f	4	6	-	mW
Optical linewidth	Δf	-	-	2	MHz
Temperature Tuning Coefficient	T_{λ}	0.07	0.1	0.14	nm/°C
Current Tuning Coefficient	I_{λ}	0.008	0.014	0.020	nm/mA
Slope Efficiency	SE	0.05	0.1	-	mW/mA
Thermistor Resistance	R_T	9.5	10	10.5	k Ω
Thermistor Temp. Coefficient	C	-	-4.4	-	%/°C

*CW bias unless otherwise stated

ABSOLUTE MAXIMUM RATINGS

PARAMETER	SYMBOL	MIN	TYP	MAX	UNIT
Forward Current	I_f	-	70	120	mA
Forward Voltage	V_f	-	1.3	1.6	V
TEC Current	I_{TEC}	-	-	1.2	A
Reverse Voltage LD	V_r	-	-	2.0	V
Reverse Voltage PD	V_{rev}	-	-	20	V
Case Temperature*	T_{Case}	-20	-	65	°C
Chip Submount Temperature	T_{Sub}	0	-	50	°C
Storage Temperature	$T_{storage}$	-40	-	85	°C

*For $T_{sub} < 25^{\circ}C$, Max Case Temperature should be derated to $T_{Case,Max} = T_{sub} + 40^{\circ}C$

PACKAGING

The REP1568-DM-B product series is offered in a 14-pin Butterfly package - Inquire for other packaging options. The standard package pinout is shown below, variations may be requested.

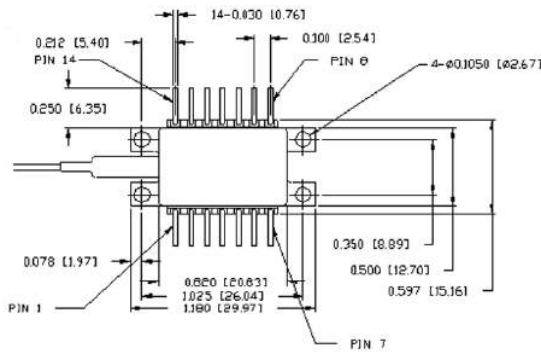

14-pin butterfly schematic

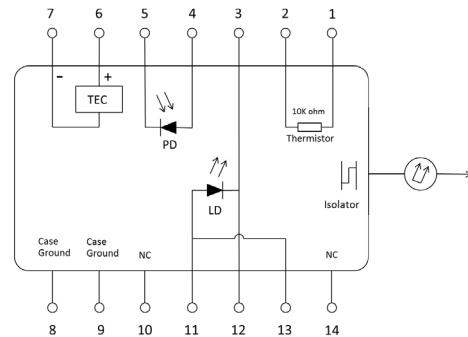

Standard "Pinout 01" option

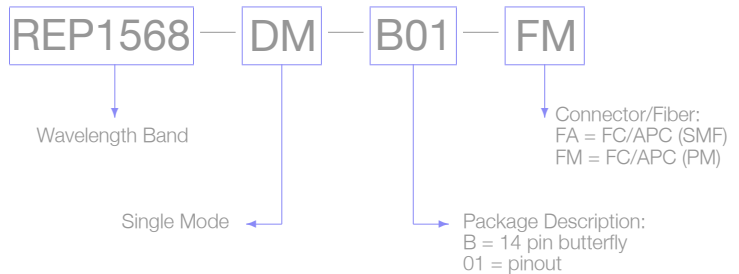

Laser Safety

This is a Class 3R Laser Product as defined by International Standard IEC 60825-1, Edition 2. Invisible Laser radiation is emitted from the end of the fiber or connector. Avoid direct eye exposure to the beam. Laser safety labels are not attached to the module due to space limitations but instead are affixed to the outside of the shipping carton.